

## How to Replace Terminals

### HOW TO REPLACE TERMINAL (with terminal retainer or secondary locking device)

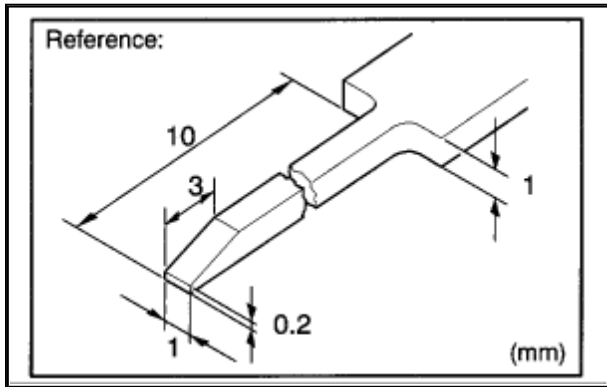

ZOOM

SIZED FOR PRINT

1. PREPARE THE SPECIAL TOOL

**HINT:** To remove the terminal from the connector, please construct and use the special tool or like object shown.

2. DISCONNECT CONNECTOR

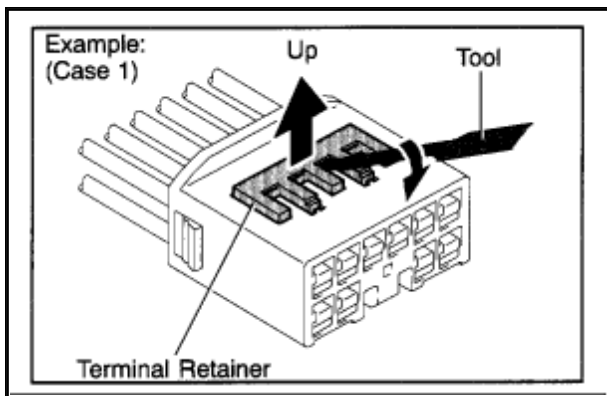

ZOOM

SIZED FOR PRINT

3. DISENGAGE THE SECONDARY LOCKING DEVICE OR TERMINAL RETAINER.

- a. Locking device must be disengaged before the terminal locking clip can be released and the terminal removed from the connector.
- b. Use a special tool or the terminal pick to unlock the secondary locking device or terminal retainer. **NOTE:** Do not remove the terminal retainer from connector body.

A: For Non-Waterproof Type Connector

**HINT:** The needle insertion position varies according to the connector's shape (number of terminals etc.), so check the position before inserting it.

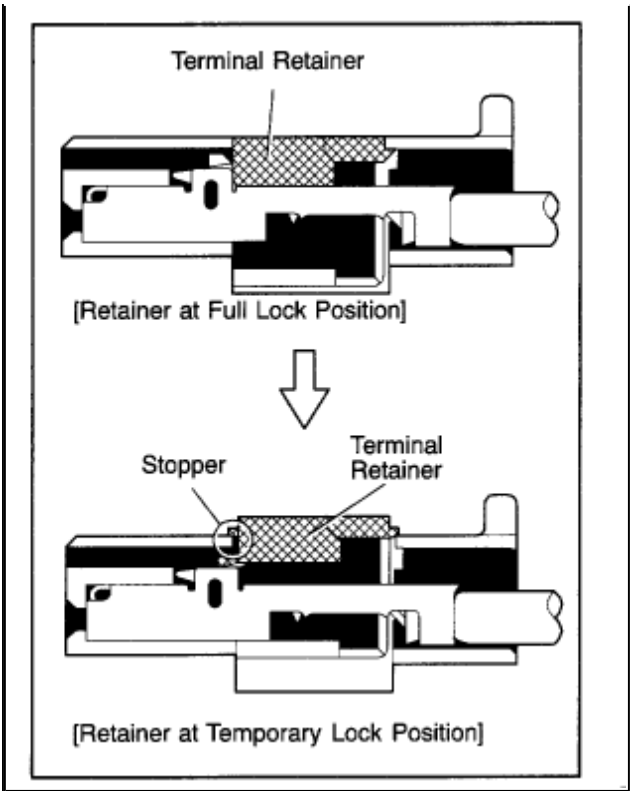

ZOOM    SIZED FOR PRINT

"Case 1"  
 Raise the terminal retainer up to the temporary lock position.

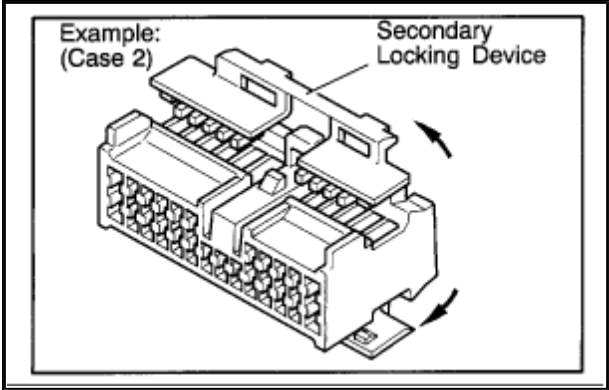

ZOOM    SIZED FOR PRINT

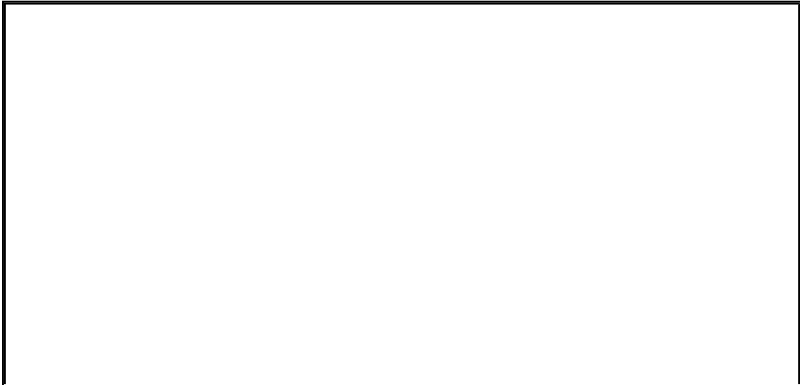

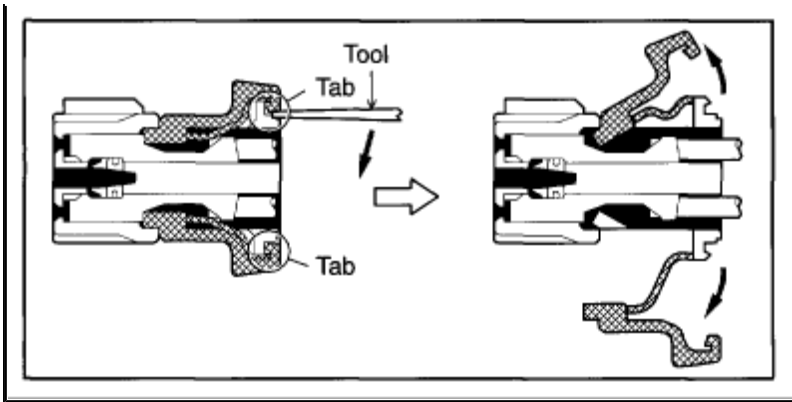

ZOOM

SIZED FOR PRINT

"Case 2"

Open the secondary locking device.

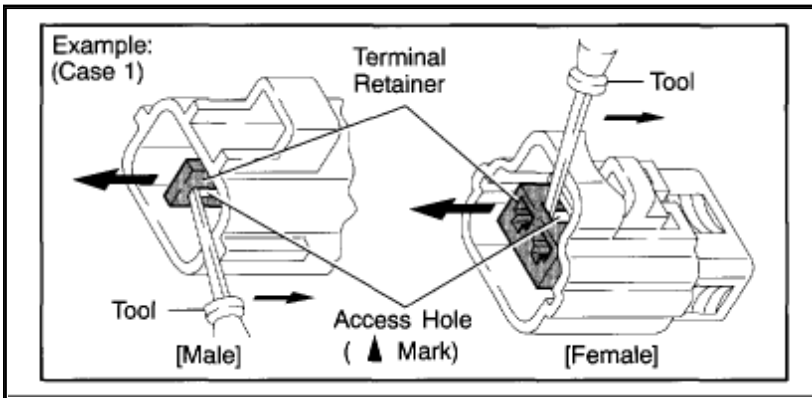

ZOOM

SIZED FOR PRINT

B: For Waterproof Type Connector

**HINT:** Terminal retainer color is different according to connector body.

Example:

Terminal Retainer : Connector Body

Black or White : Gray

Black or White : Dark Gray

Gray or White : Black



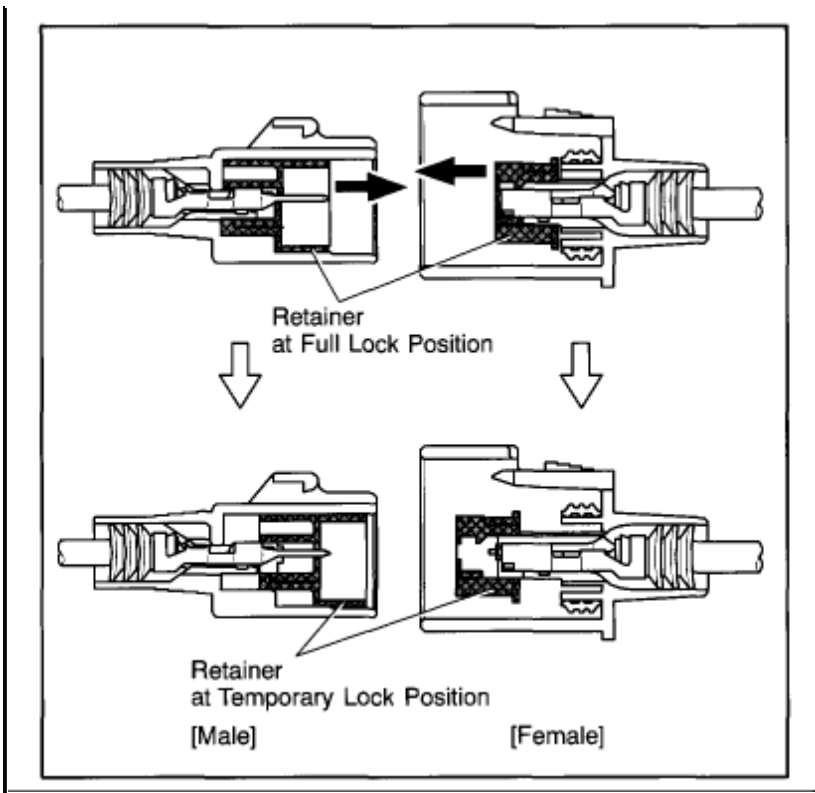

ZOOM    SIZED FOR PRINT

"Case 1"

Type where terminal retainer is pulled up to the temporary lock position (Pull Type).

Insert the special tool into the terminal retainer access hole (Mark) and pull the terminal retainer up to the temporary lock position.

**HINT:** The needle insertion position varies according to the connector's shape (Number of terminals etc.), so check the position before inserting it.

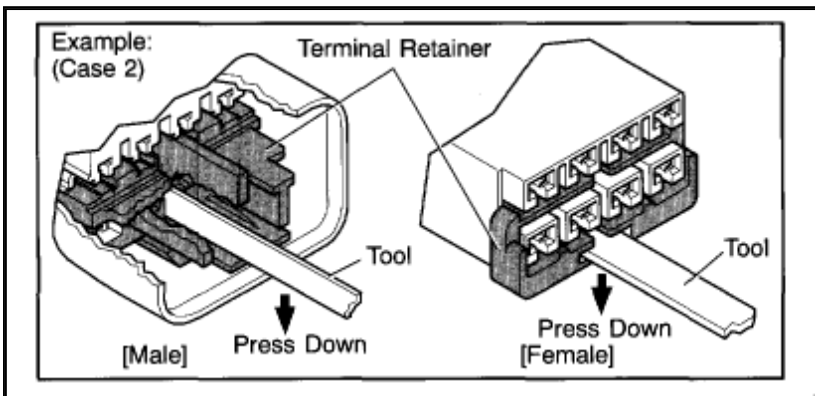

ZOOM    SIZED FOR PRINT

"Case 2"

Type which cannot be pulled as far as Power Lock insert the tool straight into the access hole of terminal retainer as shown.

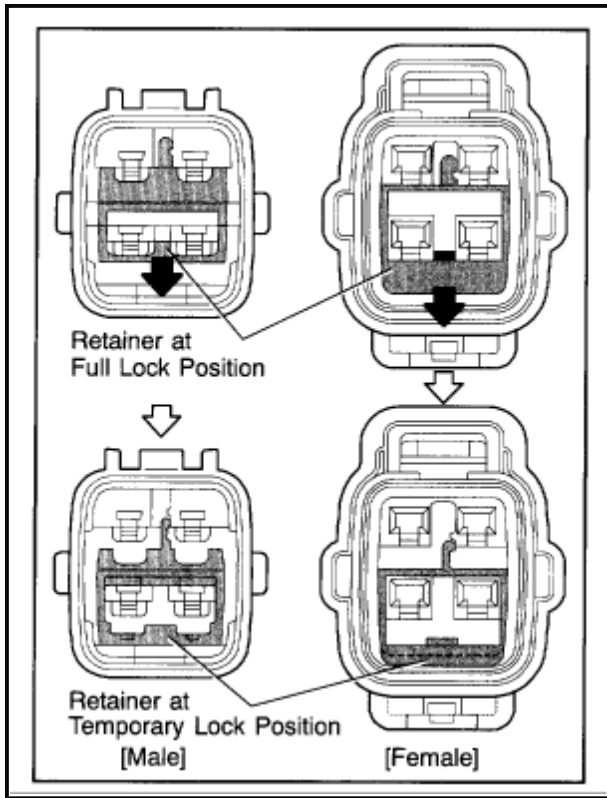

ZOOM    SIZED FOR PRINT

Push the terminal retainer down to the temporary lock position.

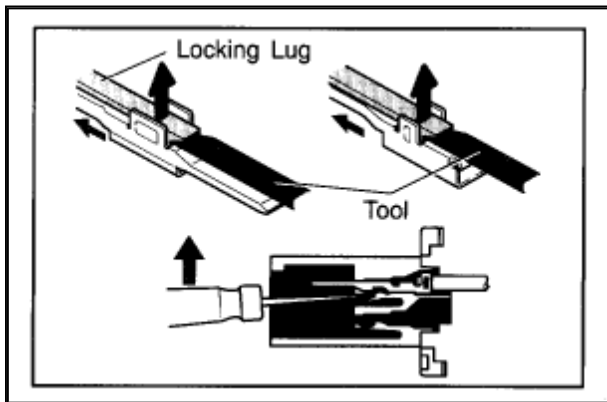

ZOOM    SIZED FOR PRINT

c. Release the locking lug from terminal and pull the terminal out from rear.

4. INSTALL TERMINAL TO CONNECTOR



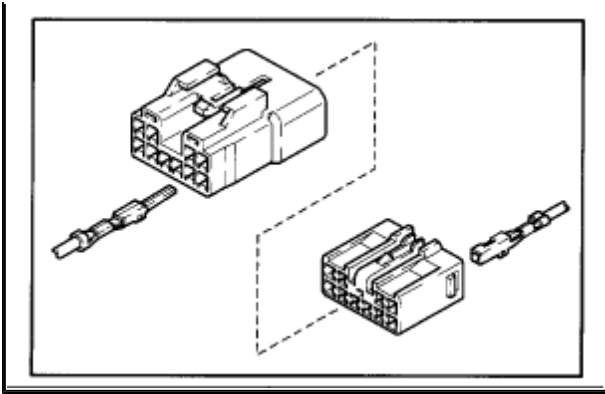

ZOOM

SIZED FOR PRINT

a. Insert the terminal. **HINT:**

1. Make sure the terminal is positioned correctly.
2. Insert the terminal until the locking lug locks firmly.
3. Insert the terminal with terminal retainer in the temporary lock position.

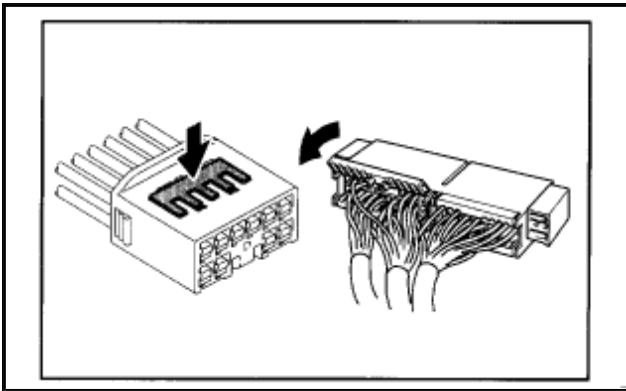

ZOOM

SIZED FOR PRINT

b. Push the secondary locking device or terminal retainer in to the full lock position.

5. CONNECT CONNECTOR