

**Rear**

**INSPECTION**

1. MEASURE VEHICLE HEIGHT
2. INSTALL CAMBER-CASTER-KINGPIN GAUGE OR POSITION VEHICLE ON [WHEEL ALIGNMENT TESTER](#) Follow the specific instructions of the equipment manufacturer.
3. INSPECT CAMBER

Camber Right-left error	$-1^{\circ}11' \pm 45'$ ( $-1.18^{\circ} \pm 0.75^{\circ}$ ) 45' (0.75°) or less
----------------------------	---

ZOOM

SIZED FOR PRINT

**Camber:**

If the camber is not within the specified value, after the toe-in is inspected, see step 5 to adjust.

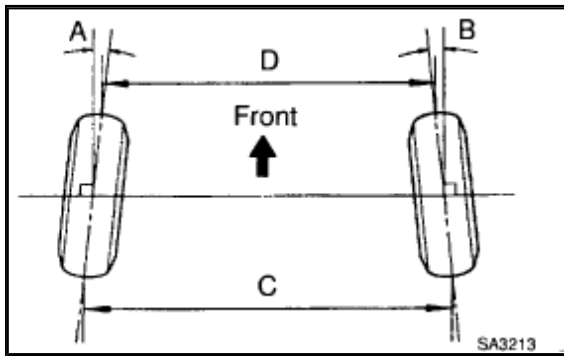

ZOOM

SIZED FOR PRINT

4. INSPECT TOE-IN

Toe-in (total)	$A + B: 0^{\circ}18' \pm 12'$ ( $0.3^{\circ} \pm 0.2^{\circ}$ ) $C - D: 3 \pm 2$ mm ( $0.12 \pm 0.08$ in.)
-------------------	---

ZOOM

SIZED FOR PRINT

**Toe-in:**

If the toe-in is not within the specified value, see step 5 to adjust.

5. ADJUST CAMBER AND TOE-IN

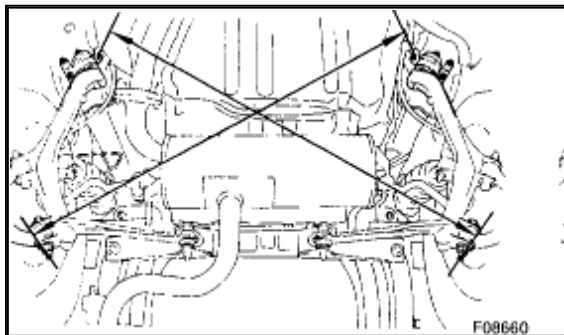

ZOOM

SIZED FOR PRINT

- Measure the distance from the LH lower suspension arm bracket set bolt to the RH axle carrier rear side set bolt as shown in the illustration.
- Employ the same manner to the RH-LH. Length difference: **6 mm or less** If it exceeds the specified value, adjust it by turning the adjusting cams.

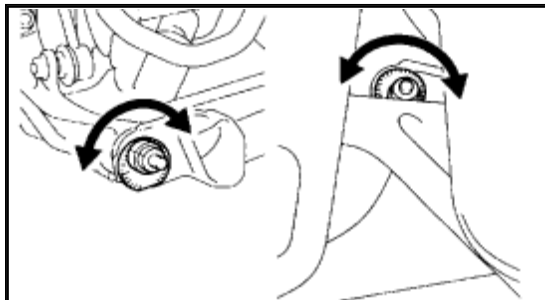

ZOOM

SIZED FOR PRINT

- Loosen the upper and lower arm adjusting cam set nuts.
- Adjust the camber and toe-in by turning the adjusting cams. **HINT:** Try to adjust the camber and toe-in to the center of the specified values.
- Torque the upper and lower arm adjusting cam set nuts. Torque: **74 Nm (755 kgf.cm, 55 ft. lbs.)**

#### 6. HOW TO READ ADJUSTMENT CHART (EXAMPLE)

- Measure the present alignment. Example: Camber (RH): **-0°26'(-0.43°)** Camber (LH): **-1°56' (-1.93°)**  
Toe-in (total): **IN 7 mm (0.28 inch)**

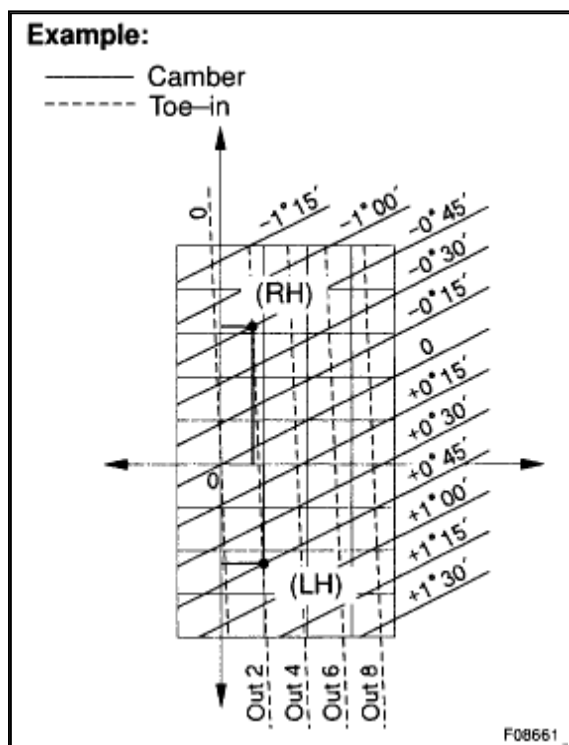

ZOOM

SIZED FOR PRINT

- b. Mark the difference between the standard value (A) and the measured value (B) on the adjustment chart. Standard value: Camber:  $-1^{\circ}11'$  ( $-1.18^{\circ}$ ) Toe-in (total): **IN 3 mm (0.12 inch)** Formula:  $A - B = C$   
 Camber (RH):  $-1^{\circ}11' - (-0^{\circ}26') = -0^{\circ}45'$  Camber (LH):  $-1^{\circ}11' - (-1^{\circ}56') = 0^{\circ}45'$  Toe-in (total): IN3 - IN7 = OUT 4 Toe-in (each side): OUT 2

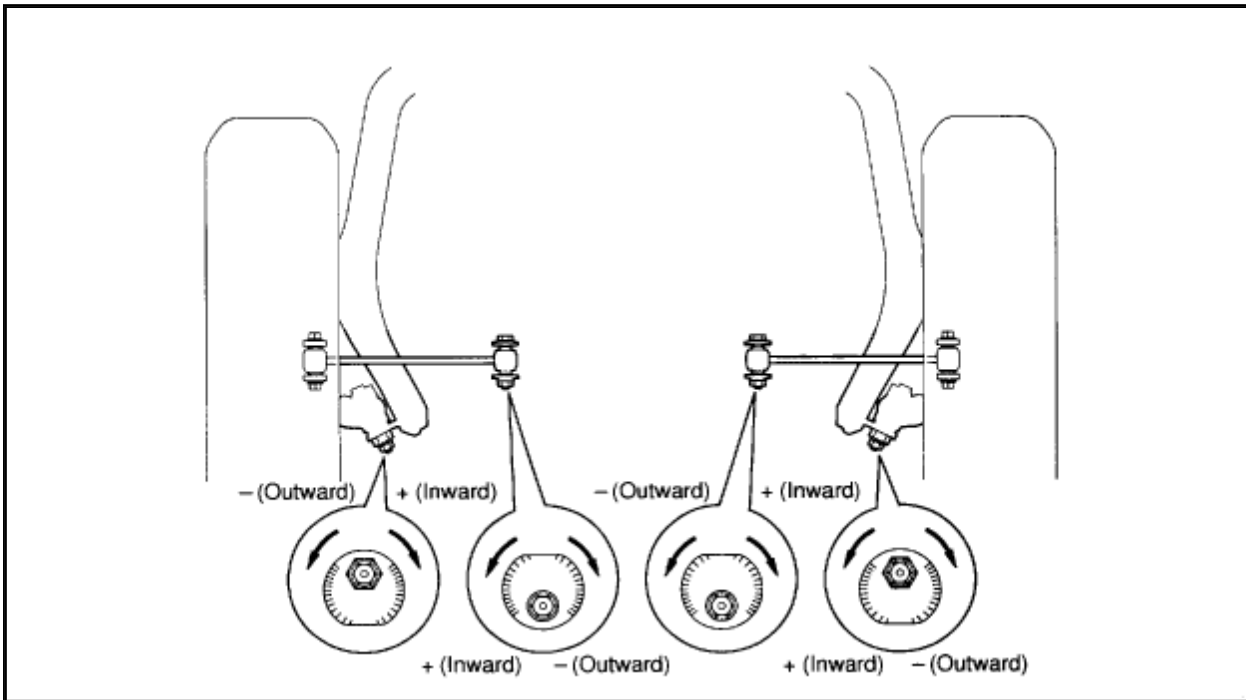

ZOOM

SIZED FOR PRINT

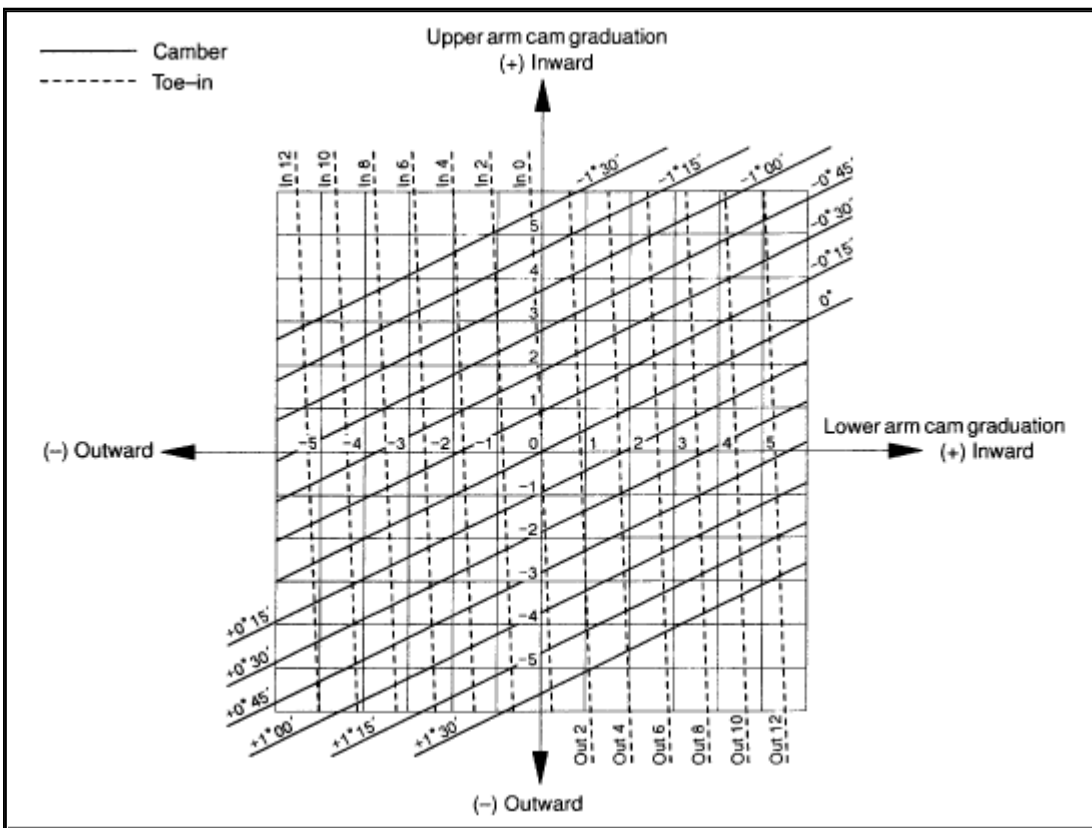

ZOOM

SIZED FOR PRINT

- c. As shown in the example chart, read the distance from the marked point to the origin of the chart, and adjust the upper and/or lower arm adjusting cams accordingly Amount to turn adjusting cams (by graduation): Upper arm cam (RH): + (Inward) 3.2 Lower arm cam (RH): + (Inward) 0.8 Upper arm cam (LH): - (Outward) 2.3 Lower arm cam (LH): + (Inward) 1.0