

Testing and Inspection

INSPECTION

1. INSPECT TIRE

- a. Check the [tires](#) for wear and proper inflation pressure. Cold tire inflation pressure

Tire size	Front kPa (kgf/cm ² , psi)	Rear kPa (kgf/cm ² , psi)
195/60R15 88H P195/60R15 87H	210 (2.1, 29)	210 (2.1, 29)

ZOOM

SIZED FOR PRINT

1ZZ-FE engine models:

Tire size	Front kPa (kgf/cm ² , psi)	Rear kPa (kgf/cm ² , psi)
205/55R15 87V P205/55R15 87V 205/50R16 87V	220 (2.2, 32)	220 (2.2, 32)

ZOOM

SIZED FOR PRINT

2ZZ-GE engine models:

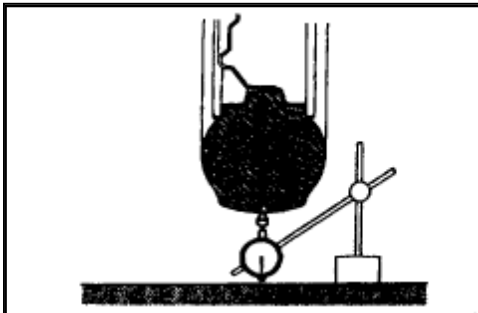

ZOOM

SIZED FOR PRINT

- b. Using a dial indicator, check the tire runout. Tire runout: **1.0 mm (0.039 inch) or less**

2. ROTATING TIRES



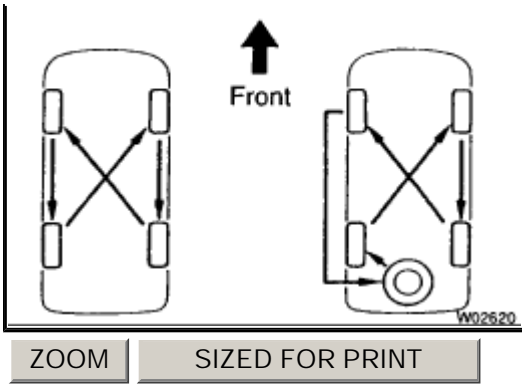

HINT: See the illustration for where to rotate each tire when you include the spare tire in the rotation and when you do not.

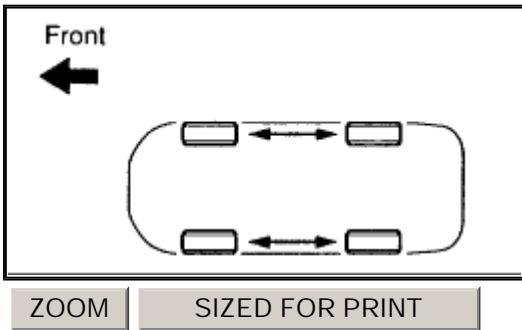

If the rotating direction is specified, do not exchange the [tires](#) between the right and left.

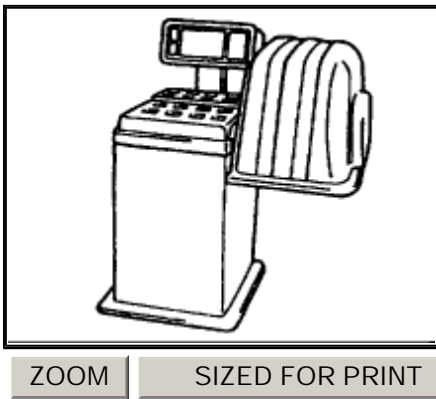

3. INSPECT WHEEL BALANCE

- a. Check and adjust the Off-the-car balance.
- b. If necessary, check and adjust the On-the-car balance. Imbalance after adjustment: **8.0 g (0.018 lbs.) or less**

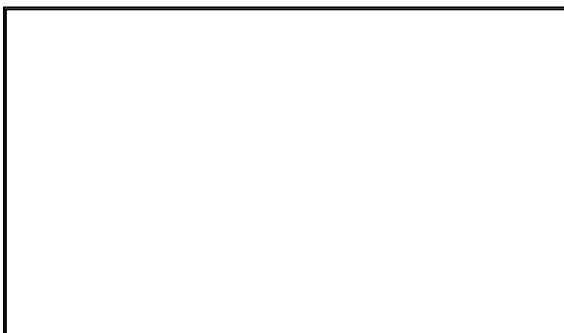

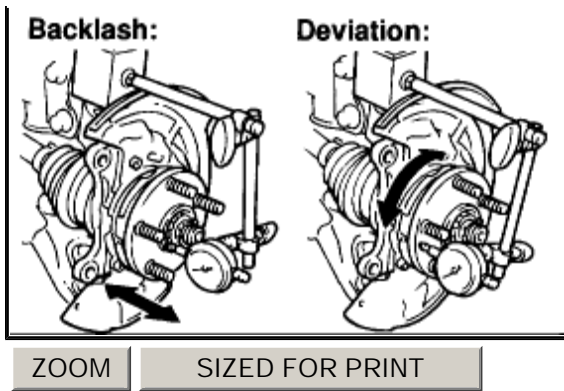

4. CHECK **WHEEL BEARING** LOOSENESS

- a. Using a dial indicator, check the backlash near the center of the axle hub. Maximum: **0.05 mm (0.0020 inch)**
If the backlash exceeds the maximum, replace the bearing.
- b. Using a dial indicator, check the deviation at the surface of the axle hub outside the hub bolt. Maximum: **0.07 mm (0.0028 inch)** If the deviation exceeds the maximum, replace the axle hub.

5. CHECK FRONT SUSPENSION FOR LOOSENESS
6. CHECK STEERING LINKAGE FOR LOOSENESS
7. CHECK BALL JOINT FOR LOOSENESS
8. CHECK SHOCK ABSORBER WORKS PROPERLY

- Check that oil leaks
- Check mounting bushings for wear
- Bounce front and rear of the vehicle